

INSERTI SEMIESAGONALI TESTA RIDOTTA SERIE STEP

SEMIEXAGONAL FLAT HEAD STEP SERIES

MATERIALI:
- ACCIAIO ZINCATO
- ACCIAIO INOX

MATERIAL:
- STEEL ZINC PLATED
- STAINLESS STEEL

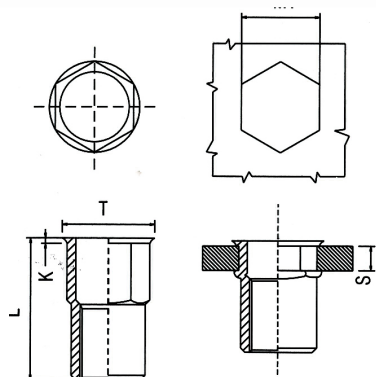

Ø Diametro Vite Screw Diameter	D	T	K	L	Diametro Foro Hole Diameter	Spessore Lamiera Sheets Thickness
M4 - C	5,9	7,2	0,5	11,2	6	0,5 - 2,0
M4 - L				13,2		1,5 - 4,0
M5 - C	6,9	8,2	0,5	13,3	7	0,5 - 3,0
M5 - L				15,8		2,0 - 5,5
M6 - C	8,9	10,5	0,6	15,3	9	0,5 - 3,0
M6 - L				17,8		2,0 - 5,5
M8 - C	10,9	13	0,7	16,7	11	0,5 - 3,5
M8 - L				19,7		2,5 - 6,5
M10 - C	11,9	15	0,8	21	13	1,0 - 3,5
M10 - L				24		2,5 - 6,5

INSERTI SEMIESAGONALI TESTA RIDOTTA CIECHI SERIE STEP-C

SEMI EXAGONAL SMALL HEAD CLOSE END

MATERIALI:
- ACCIAIO ZINCATO
- ACCIAIO INOX

MATERIAL:
- STEEL ZINC PLATED
- STAINLESS STEEL

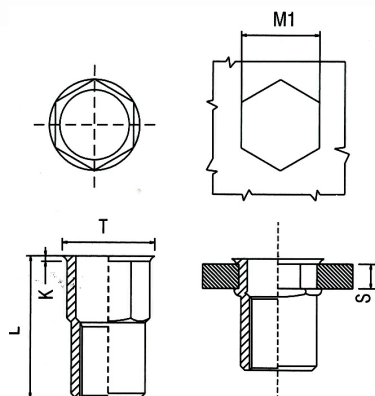

Ø Diametro Vite Screw Diameter	D	T	K	L	Diametro Foro Hole Diameter	Spessore Lamiera Sheets Thickness
M4	5,9	7	0,5	16,5	6	0,5 - 2,0
M5	6,9	8	0,6	18,5	7	0,5 - 2,5
M6	8,9	10	0,6	23	9	0,5 - 3,0
M8	10,9	12,5	0,6	26,5	11	0,5 - 3,5

